

ISSUE	DETAILS	DATE
A	TO BE APPROVED FOR MANUFACTURE	

FITTING POSITIONS SHOWN ARE STANDARD. PLEASE INDICATE WITH DIMENSIONS IF REQUIRED IN A DIFFERENT LOCATION.
TANK SHOWN IS SUITABLE FOR VDO STYLE SENDER (WITH PICKUP / RETURN PIPES IN SENDER UNIT).

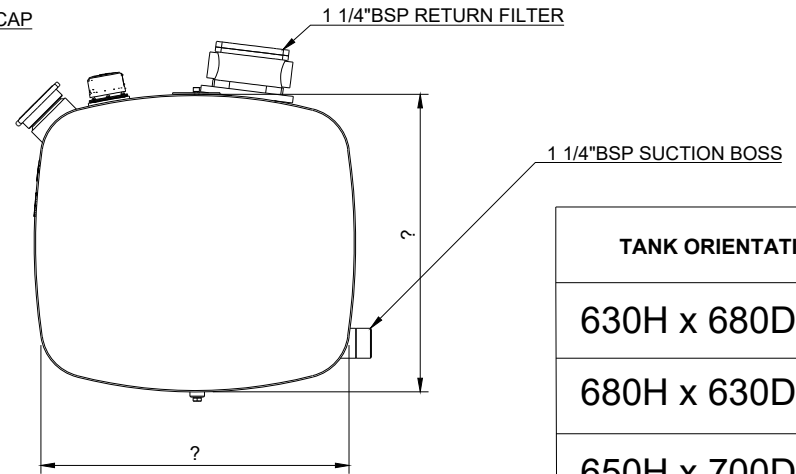
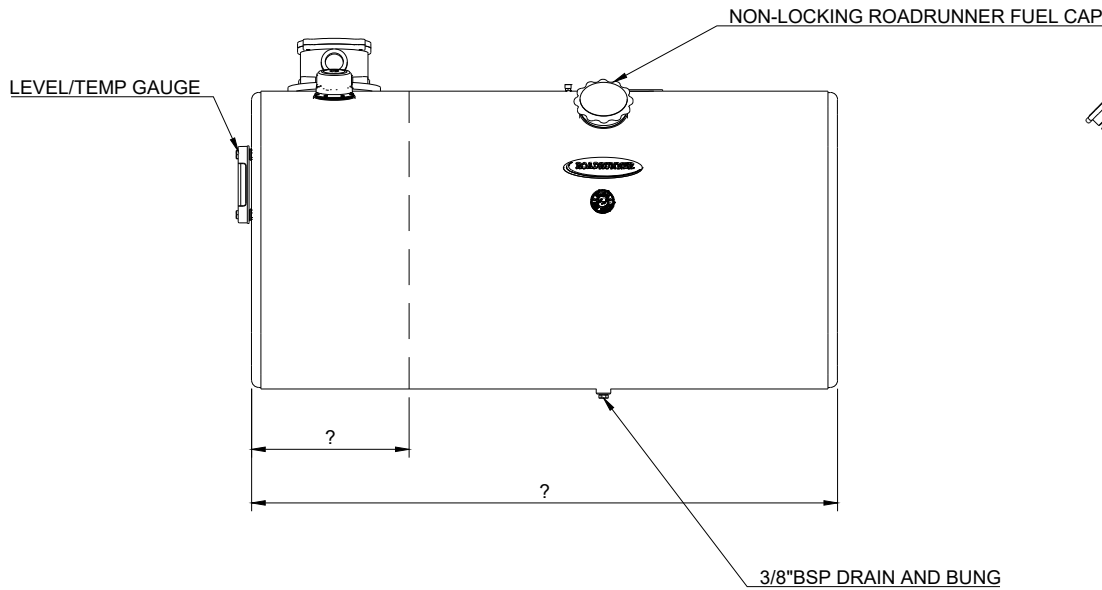
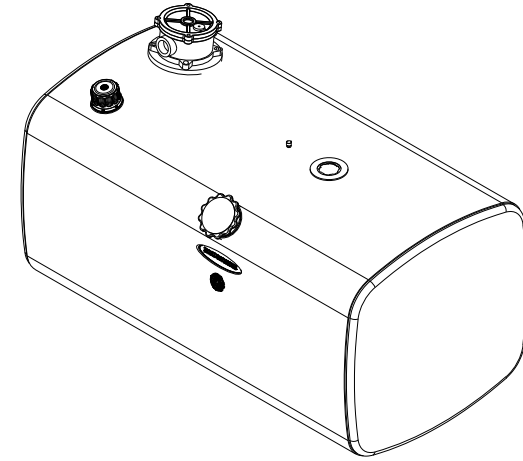
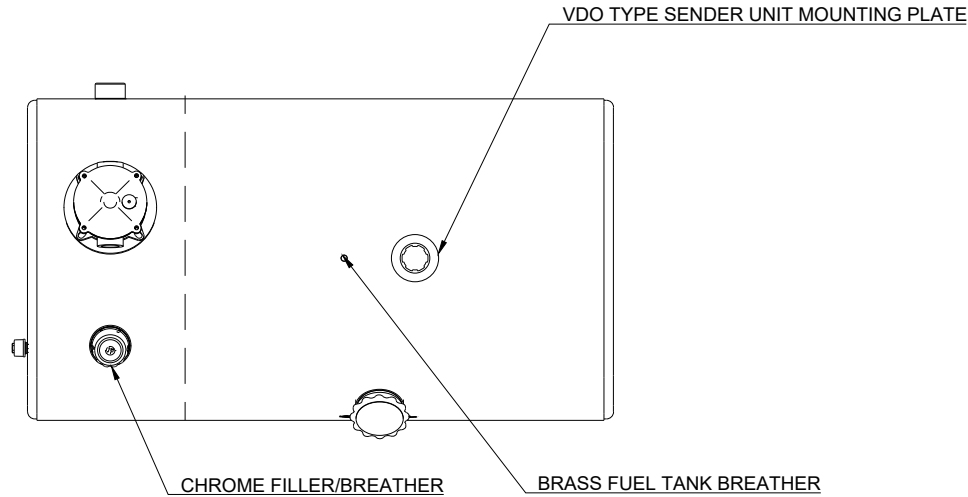

TANK ORIENTATION	
630H x 680D	
680H x 630D	
650H x 700D	
700H x 650D	

THIS DRAWING AND/OR ELECTRONIC MEDIA CONTAINING THIS DRAWING REMAIN THE PROPERTY OF ROADRUNNER MANUFACTURING LTD. IT MAY NOT BE COPIED OR USED IN ANY UNORTHERISED MANNER



CLIENT:			SHEET:
TITLE: Oval Sq Combo Tank - VDO Sender	DATE:	SCALE: 1:16	1/1
DRAWN BY: Steve Tunncliffe	PRODUCT CODE:	JOB NUMBER	ISSUE: